



Unlacquered Brass Custom Form

Contact quotes@infinitydrain.com for pricing and lead time.

Developing a Patina

Color Changes: Unlacquered brass surface transitions from golden to darker shades of brown, bronze, or amber. In humid or salty environments, it may develop hints of green or blue, called verdigris (copper carbonate compounds).

Texture: The patina often has an uneven, organic texture, adding depth and character to the surface.

1. Choose Grate Style (Made from brass or brass plated)

BRASS

Drains are crafted from authentic unlacquered brass sheets. This approach ensures a true living finish that will naturally age and develop a patina over time.

- OFFSET SLOTTED (1.5" wide)**
 - OFFSET SLOTTED (2.5" wide)**
 - ADHESION**
 - CIRCLE**
 - SOLID**
-

BRASS PLATED

Drains with a stainless steel core with a high-quality unlacquered brass plating, delivering both durability and the luxurious patina effect of a living finish.

- WEDGE WIRE (1.5" wide)**
 - WEDGE WIRE (4" wide)**
 - WEDGE WIRE (2.5" wide)**
 - TILE INSERT FRAME**
 - TILE INSERT FRAME**
-
- 3/8" Depth for Tile

Rate of Patina Development: Plated finishes may develop a patina more gradually compared to solid brass, as the layer of metal is thinner. The depth and character of the patina may vary based on the thickness of the plating and the specific environmental conditions.

Durability: Plated finishes offer the aesthetic appeal of brass combined with the strength of stainless steel. However, because plating is a surface treatment, heavy abrasion or scratches could potentially reveal the underlying stainless steel. Despite this, with regular exposure to the elements and proper care, the plating will still achieve the desired aged look.

2. Choose Channel

- FF Fixed Flange**
1" Flange
2" No Hub Outlet
 - FCS Flange with KERDI**
Factory applied KERDI
1" Flange for Wall to Wall
2" No Hub Outlet
 - FCB Double Waterproofing**
1" Flange
2" Threaded Outlet**
-

3. Choose Length & Outlet Location(s) - (Up to 96" length)

A: Overall Inside Length (FF, FCB, FCS) A: Overall Length (FX)	B1: Outlet Location 1	B2: Outlet Location 2 <i>(For additional outlet if needed)</i>
---	------------------------------	--

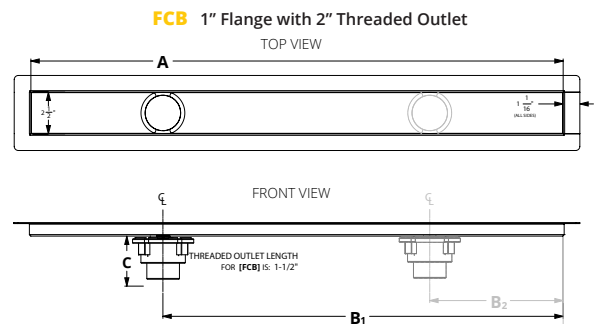
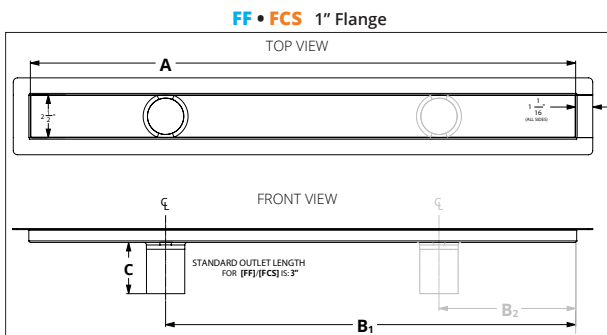

By signing this form, you are agreeing to the terms and conditions herein. All details and finishes stated are correct. All dimensions are correct and are to be held within a tolerance of +/- 1/16". All other details and dimensions that are specified as "standard" are subject to manufacturer's tolerance and change without notice. We can assume no responsibility for use of superseded or void data. All custom orders are non-cancellable, non-returnable and non-refundable.

Infinity Drain
145 Dixon Avenue
Amityville, NY 11701
Phone: 516.767.6786
Fax: 516.740.3066
www.infinitydrain.com



APPROVAL	NAME	PO #/REFERENCE
	SIGNATURE	DATE