

# FTMN 25 Series

## FTMN 25 | Fixed Length

- 14 gauge 304 Stainless Steel grate
- 16 gauge 304 Stainless Steel channel
- Pre-pitched channel with "Fixed" lengths and "Fixed" center side "tunnel" outlet location
- Not site sizeable
- Indoor or outdoor use
- Bonded "Flange" installation for flush against the wall
- Allows waste line to connect horizontally to save floor height and waste line relocation
- Lowest height for curbless installations
- Uses Liquid and Fabric Sheet Membrane waterproofing
- Grate can be removed completely for cleaning
- Flow rate 9 GPM per outlet\*

\*Flow rate measured at outlet only. Measurement does not account for water in channel or sheeting on shower floor.

### Finishes:

- \_\_\_ Satin Stainless
- \_\_\_ Polished Stainless
- \_\_\_ Lifetime Oil
- \_\_\_ Rubbed Bronze
- \_\_\_ Matte White
- \_\_\_ Matte Black

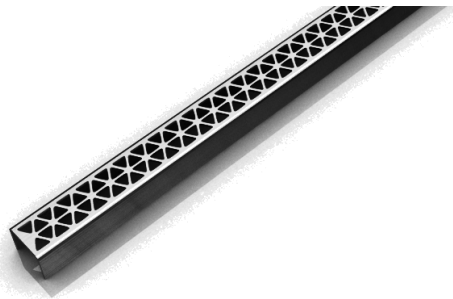

### Complete Kits:

- FTMN 2532 32" Complete Kit
- FTMN 2536 36" Complete Kit
- FTMN 2542 42" Complete Kit
- FTMN 2548 48" Complete Kit
- FTMN 2560 60" Complete Kit

### Components:

- MA 2532 32" Stainless Steel Grate
- MA 2536 36" Stainless Steel Grate
- MA 2542 42" Stainless Steel Grate
- MA 2548 48" Stainless Steel Grate
- MA 2560 60" Stainless Steel Grate
- OC 6532 32" Fixed Flange Channel
- OC 6536 36" Fixed Flange Channel
- OC 6542 42" Fixed Flange Channel
- OC 6548 48" Fixed Flange Channel
- OC 6560 60" Fixed Flange Channel
- CI 2532 32" Channel Insert
- CI 2536 36" Channel Insert
- CI 2542 42" Channel Insert
- CI 2548 48" Channel Insert
- CI 2560 60" Channel Insert

## Installation (FT) Flange Tunnel

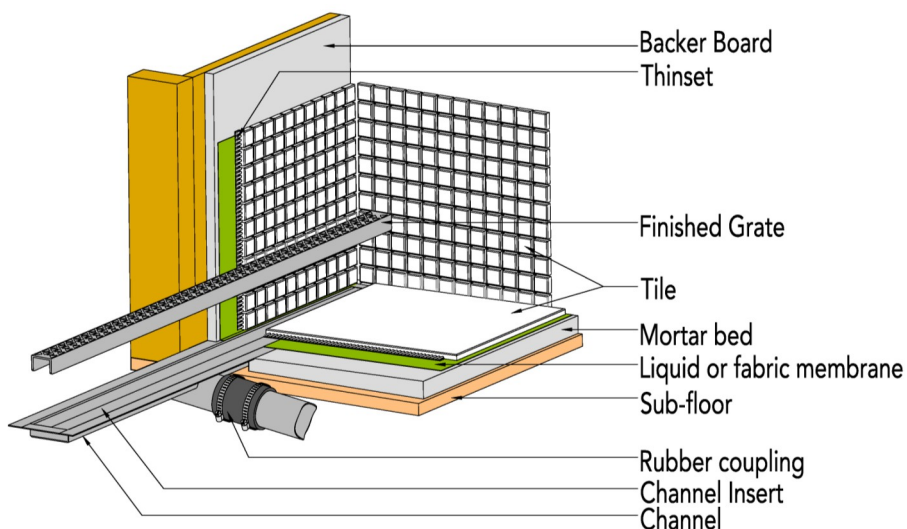

### Infinity Drain

18 Secatoag Avenue  
Port Washington, NY 11050  
Phone: 516.767.6786  
Fax: 516.740.3066  
www.InfinityDrain.com

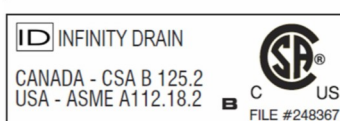

**Note:** Installer must verify all rough-in dimensions prior to installation and consult local and national codes. Conformity and compliance to local and national codes are the responsibility of the installer.

# FTMN 2542 Specifications

**ID** Infinity Drain

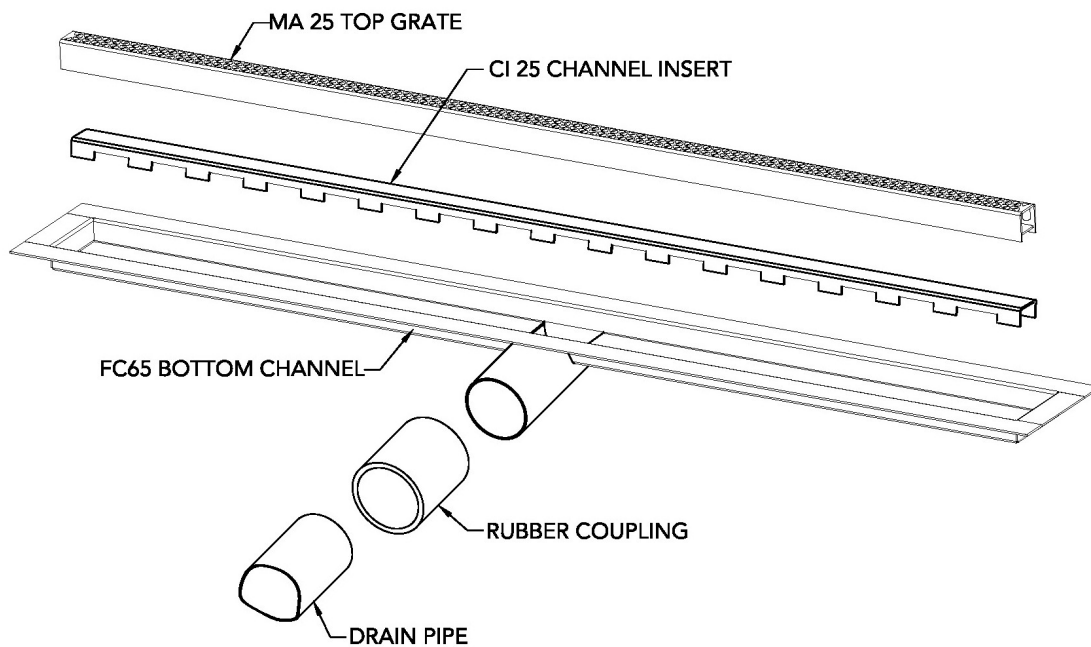
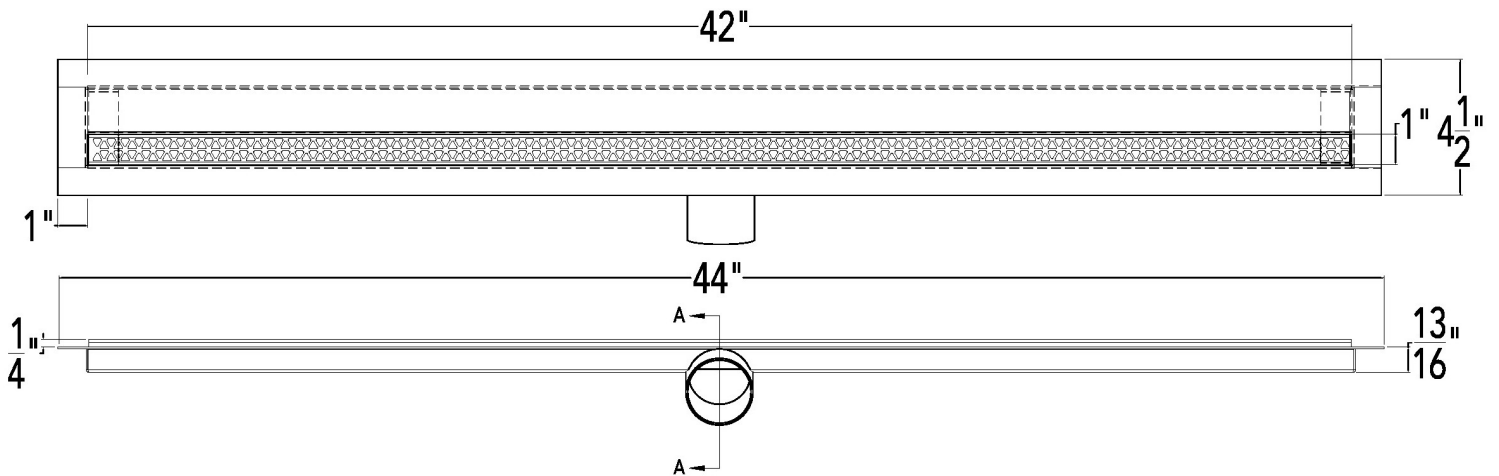

(SCREWS CAN BE ADJUSTED FOR UP TO 1/2" ADDITIONAL HEIGHT)

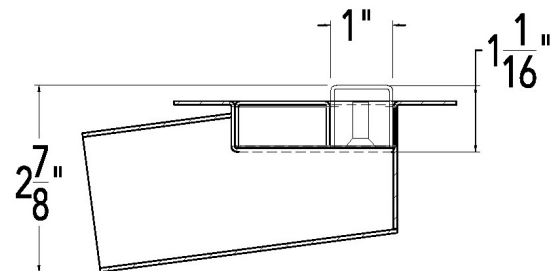

SECTION A-A

## FTMN 2542

### 42" Complete Kit Includes:

(44 1/8" l x 4 1/2" w x 1 3/16" h)

- 1 - MA 2542 Grate
- 1 - OC 6542 Fixed Flange Channel
- 1 - CI 2542 Channel Insert

## Infinity Drain

18 Secatoag Avenue  
 Port Washington, NY 11050  
 Phone: 516.767.6786  
 Fax: 516.740.3066  
 www.InfinityDrain.com

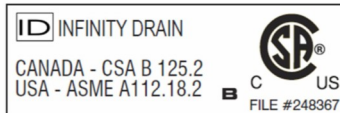

**Note:** Installer must verify all rough-in dimensions prior to installation and consult local and national codes. Conformity and compliance to local and national codes