

# FTDG 65 Series



## FTDG 65 | Fixed Length

- 16 gauge 304 Stainless Steel grate and channel
- Pre-pitched channel with "Fixed" lengths and "Fixed" center side "tunnel" outlet location
- Not site sizeable
- Indoor or outdoor use
- Bonded "Flange" installation for flush against the wall
- Allows waste line to connect horizontally to save floor height and waste line relocation
- Lowest height for curbless installations
- Uses Liquid and Fabric Sheet Membrane waterproofing
- Grate can be removed completely for cleaning
- Flow rate 9 GPM per outlet\*

\*Flow rate measured at outlet only. Measurement does not account for water in channel or sheeting on shower floor.

### Finishes:

- \_\_\_ Satin Stainless
- \_\_\_ Polished Stainless

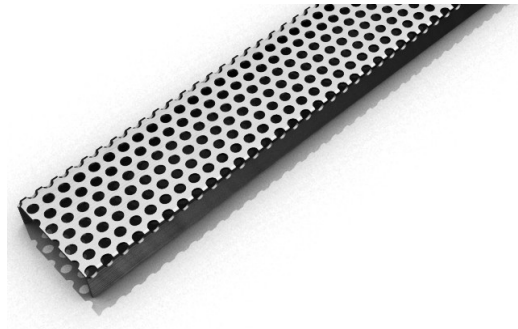

## Installation (FT) Flange Tunnel

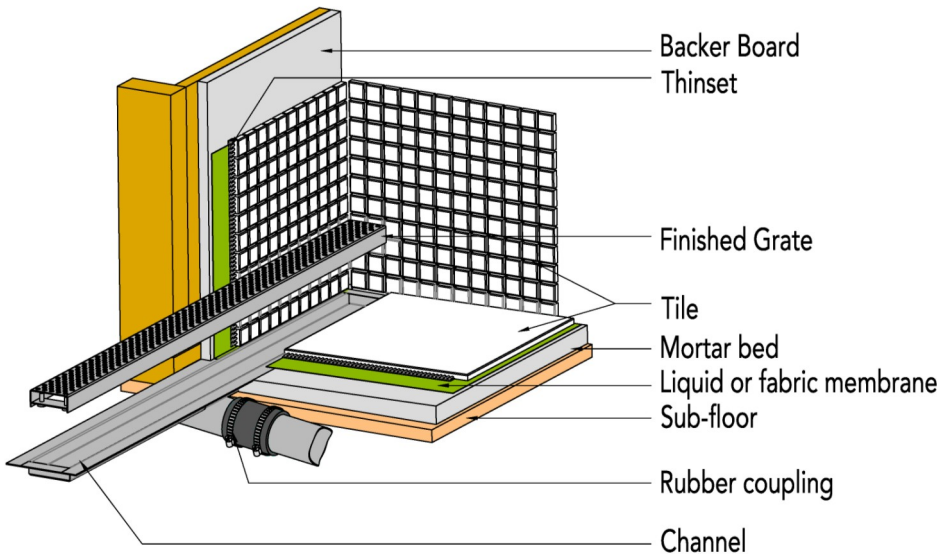

### Complete Kits:

- FTDG 6532 32" Complete Kit
- FTDG 6536 36" Complete Kit
- FTDG 6542 42" Complete Kit
- FTDG 6548 48" Complete Kit
- FTDG 6560 60" Complete Kit

### Components:

- DA 6532 32" Stainless Steel Grate
- DA 6536 36" Stainless Steel Grate
- DA 6542 42" Stainless Steel Grate
- DA 6548 48" Stainless Steel Grate
- DA 6560 60" Stainless Steel Grate
- OC 6532 32" Fixed Flange Channel
- OC 6536 36" Fixed Flange Channel
- OC 6542 42" Fixed Flange Channel
- OC 6548 48" Fixed Flange Channel
- OC 6560 60" Fixed Flange Channel

**Infinity Drain**  
 18 Secatoag Avenue  
 Port Washington, NY 11050  
 Phone: 516.767.6786  
 Fax: 516.740.3066  
 www.InfinityDrain.com

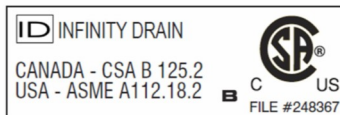

**Note:** Installer must verify all rough-in dimensions prior to installation and consult local and national codes. Conformity and compliance to local and national codes are the responsibility of the installer.

# FTDG 6548 Specifications

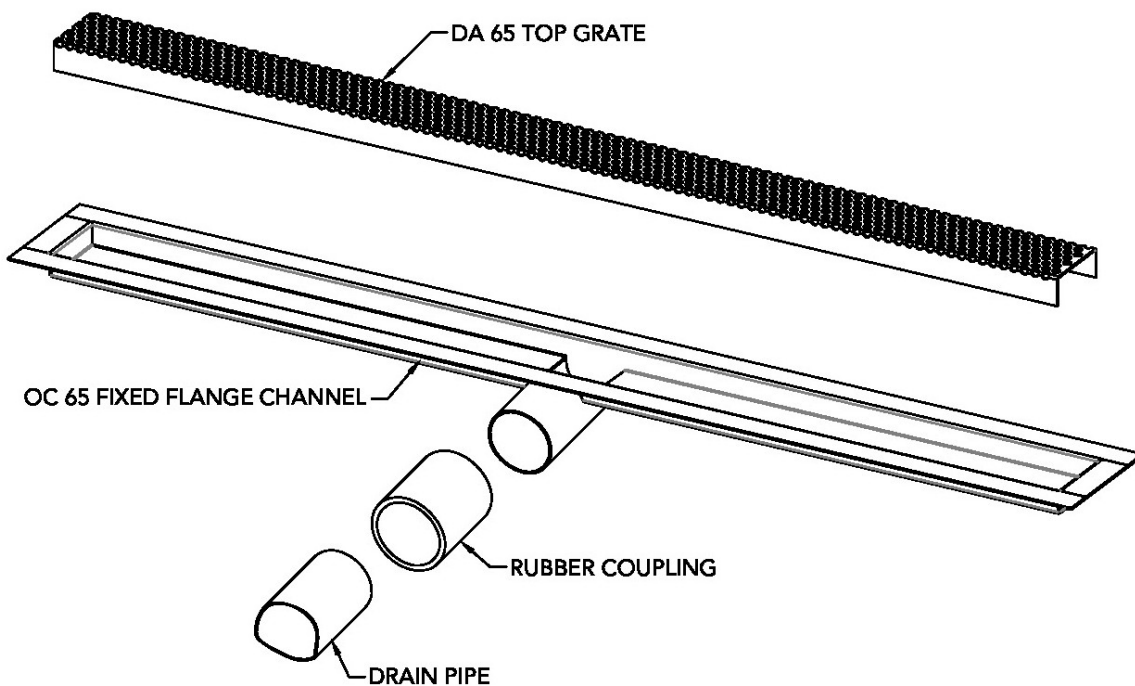
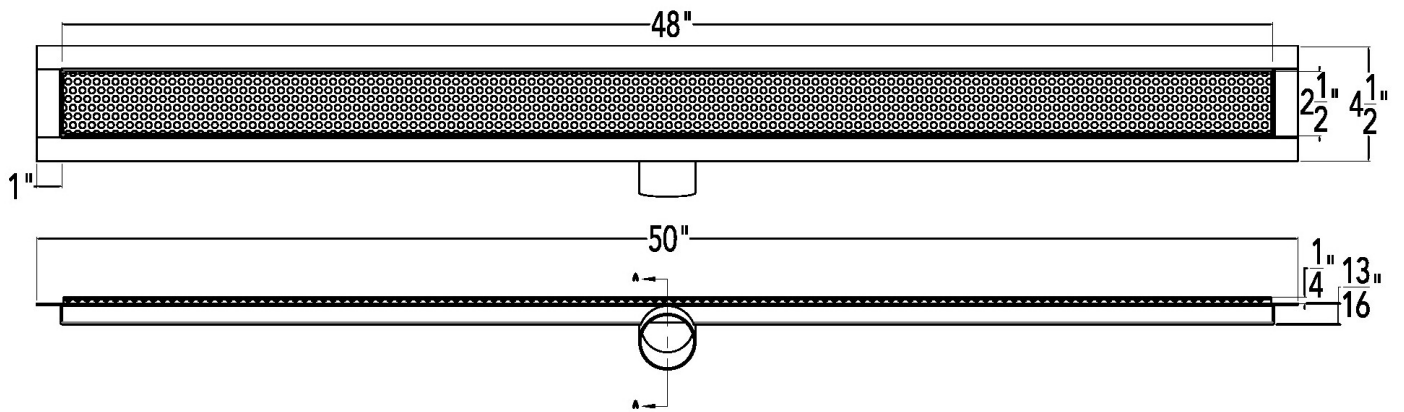

DRAIN CAN BE ADJUSTED UPWARD FOR AN ADDITIONAL 1/2" IN HEIGHT

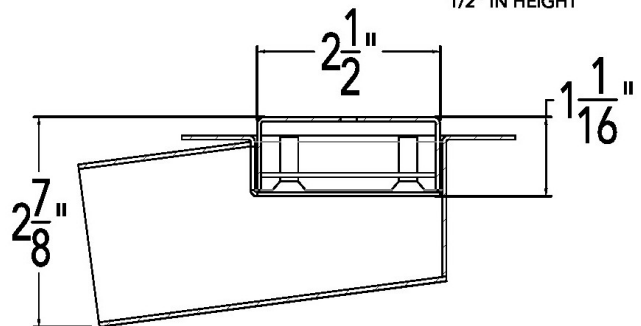

SECTION A-A

## FTDG 6548

### 48" Complete Kit Includes:

(50 1/8" l x 4 1/2" w x 1 3/16" h)

1 - DA 6548 Grate

1 - OC 6548 Fixed Flange Channel

## Infinity Drain

18 Secatoag Avenue  
Port Washington, NY 11050  
Phone: 516.767.6786  
Fax: 516.740.3066  
www.InfinityDrain.com

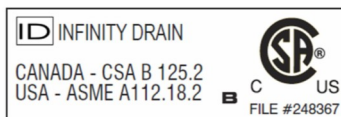

**Note:** Installer must verify all rough-in dimensions prior to installation and consult local and national codes. Conformity and compliance to local and national codes are the responsibility of the installer.