

FTAS 65 Series



FTAS 65 | Fixed Length

- 12 gauge 316 Stainless Steel grate
- 16 gauge 304 Stainless Steel channel
- Pre-pitched channel with "Fixed" lengths and "Fixed" center side "tunnel" outlet location
- Not site sizeable
- Indoor or outdoor use
- Bonded "Flange" installation for flush against the wall
- Allows waste line to connect horizontally to save floor height and waste line relocation
- Lowest height for curbless installations
- Uses Liquid and Fabric Sheet Membrane waterproofing
- Grate can be removed completely for cleaning
- Flow rate 9 GPM per outlet*

*Flow rate measured at outlet only. Measurement does not account for water in channel or sheeting on shower floor.

Finishes:

- ___ Satin Stainless
- ___ Polished Stainless
- ___ Matte White
- ___ Matte Black

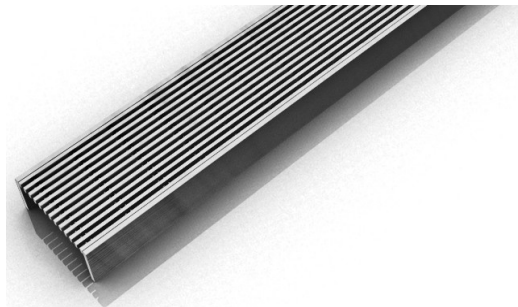

Installation (FT) Flange Tunnel

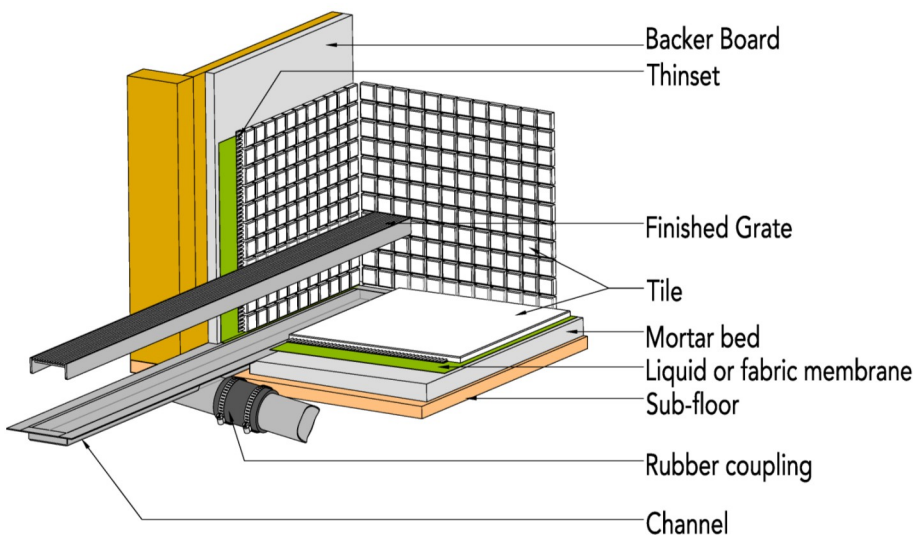

Complete Kits:

FTAS 6524	24" Complete Kit
FTAS 6532	32" Complete Kit
FTAS 6536	36" Complete Kit
FTAS 6542	42" Complete Kit
FTAS 6548	48" Complete Kit
FTAS 6560	60" Complete Kit

Components:

SA 6524	24" Stainless Steel Grate
SA 6532	32" Stainless Steel Grate
SA 6536	36" Stainless Steel Grate
SA 6542	42" Stainless Steel Grate
SA 6548	48" Stainless Steel Grate
SA 6560	60" Stainless Steel Grate
OC 6532	32" Fixed Flange Channel
OC 6536	36" Fixed Flange Channel
OC 6542	42" Fixed Flange Channel
OC 6548	48" Fixed Flange Channel
OC 6560	60" Fixed Flange Channel

Infinity Drain

18 Secatoag Avenue
Port Washington, NY 11050
Phone: 516.767.6786
Fax: 516.740.3066
www.InfinityDrain.com

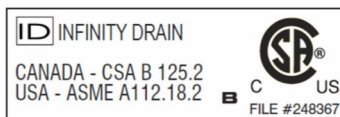

Note: Installer must verify all rough-in dimensions prior to installation and consult local and national codes. Conformity and compliance to local and national codes are the responsibility of the installer.

FTAS 6524 Specifications

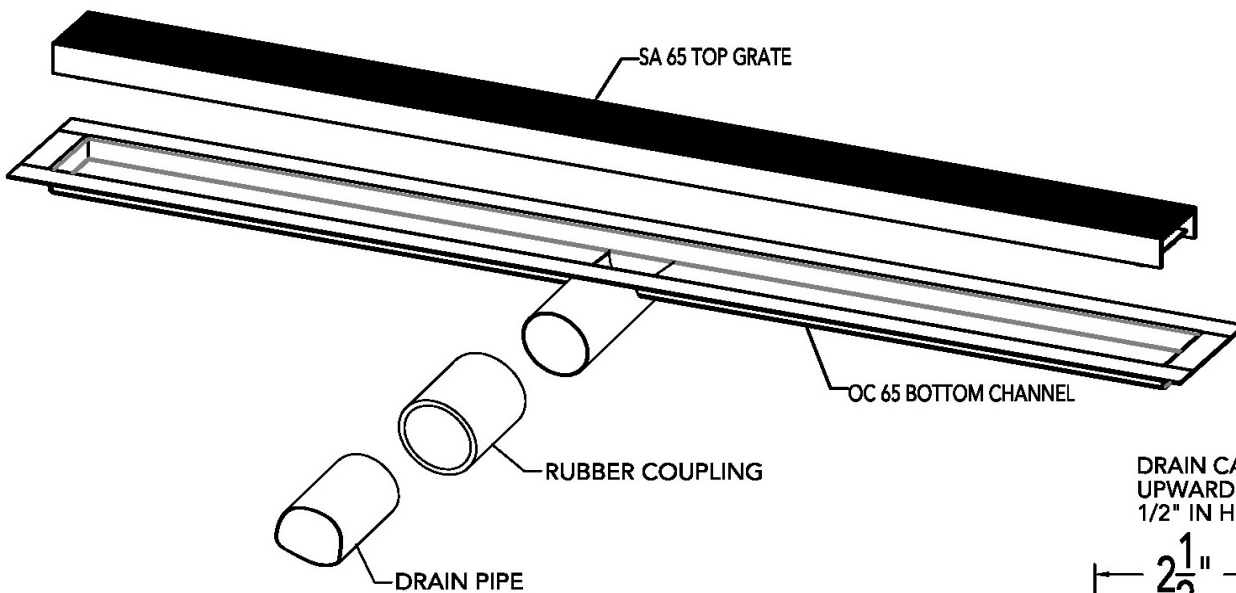
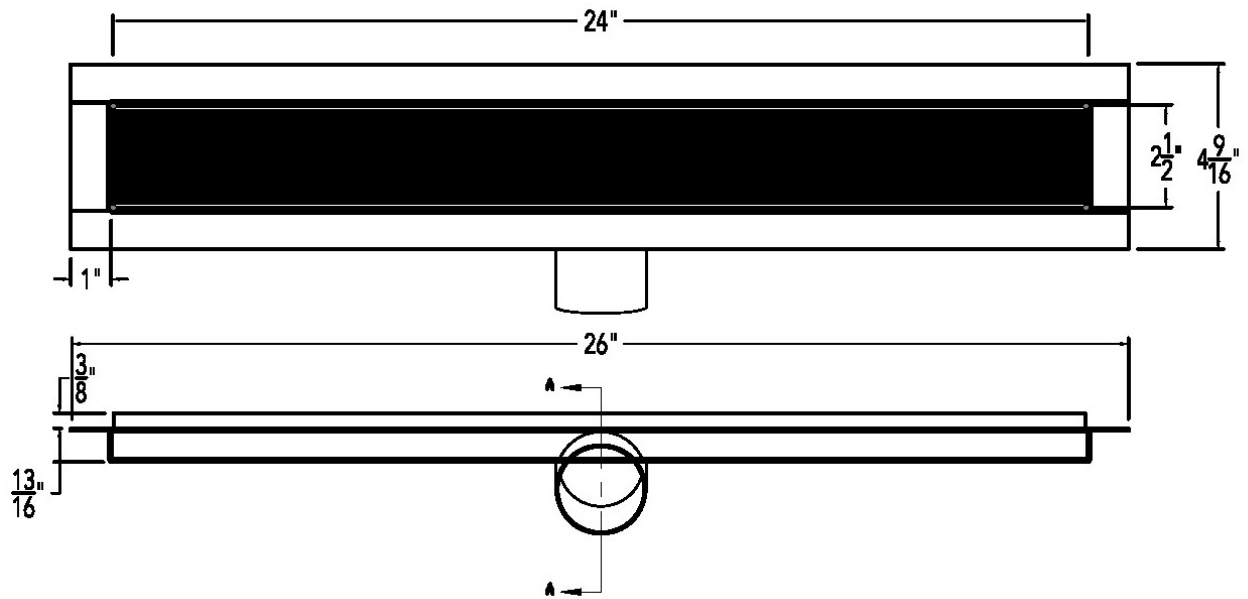

DRAIN CAN BE ADJUSTED UPWARD FOR AN ADDITIONAL 1/2" IN HEIGHT

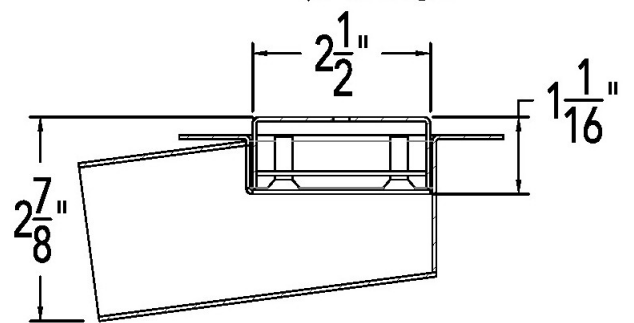

SECTION A-A

FTAS 6524

24" Complete Kit Includes:

(26 1/8" l x 4 1/2" w x 1 3/16" h)

1 - SA 6524 Grate

1 - OC 6524 Fixed Flange Channel

Infinity Drain

18 Secatoag Avenue
Port Washington, NY 11050
Phone: 516.767.6786
Fax: 516.740.3066
www.InfinityDrain.com

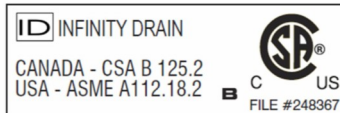

Note: Installer must verify all rough-in dimensions prior to installation and consult local and national codes. Conformity and compliance to local and national codes are the responsibility of the installer.