

# FFAS 25 Series

## FFAS 25 | Fixed Length

- 12 gauge 316 Stainless Steel grate
- 16 gauge 304 Stainless Steel channel
- Pre-pitched channel with "Fixed" lengths and "Fixed" center vertical (down) outlet location
- Not site sizeable
- Indoor or outdoor use
- Bonded "Flange" installation for flush against the wall.
- Lowest height for curbless installations
- Uses Liquid and Fabric Sheet Membrane waterproofing
- Grate can be removed completely for cleaning
- Flow rate 9 GPM per outlet\*

\*Flow rate measured at outlet only. Measurement does not account for water in channel or sheeting on shower floor.

### Finishes:

- Satin Stainless
- Polished Stainless

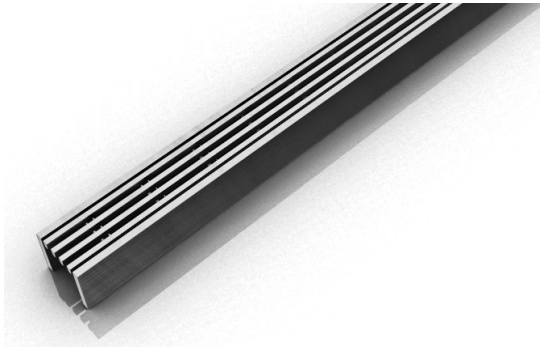

### Complete Kits:

FFAS 2532	32" Complete Kit
FFAS 2536	36" Complete Kit
FFAS 2542	42" Complete Kit
FFAS 2548	48" Complete Kit
FFAS 2560	60" Complete Kit

### Components:

SA 2532	32" Stainless Steel Grate
SA 2536	36" Stainless Steel Grate
SA 2542	42" Stainless Steel Grate
SA 2548	48" Stainless Steel Grate
SA 2560	60" Stainless Steel Grate
FC 6532	32" Stainless Steel Fixed Channel
FC 6536	36" Stainless Steel Fixed Channel
FC 6542	42" Stainless Steel Fixed Channel
FC 6548	48" Stainless Steel Fixed Channel
FC 6560	60" Stainless Steel Fixed Channel
CI 2532	32" Channel Insert
CI 2536	36" Channel Insert
CI 2542	42" Channel Insert
CI 2548	48" Channel Insert
CI 2560	60" Channel Insert

## Installation (FF) Fixed Flange

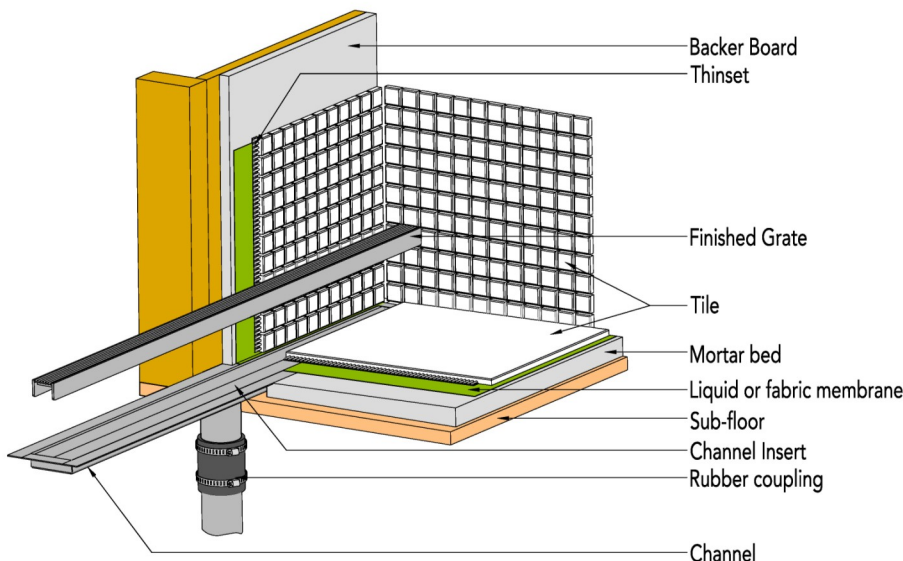

### Infinity Drain

18 Secatoag Avenue  
 Port Washington, NY 11050  
 Phone: 516.767.6786  
 Fax: 516.740.3066  
 www.InfinityDrain.com

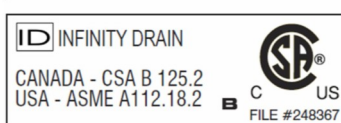

**Note:** Installer must verify all rough-in dimensions prior to installation and consult local and national codes. Conformity and compliance to local and national codes are the responsibility of the installer.

# FFAS 2532 Specifications

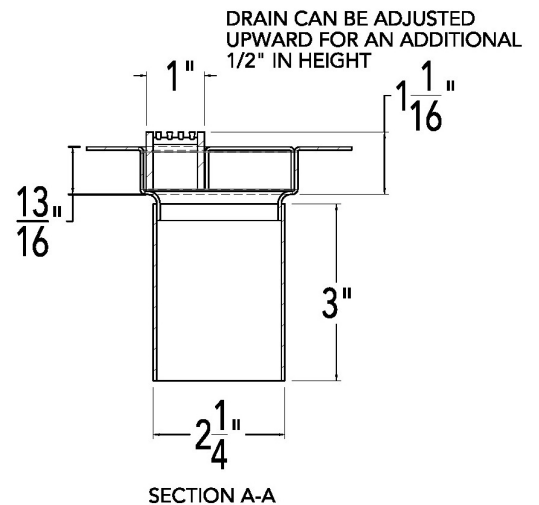
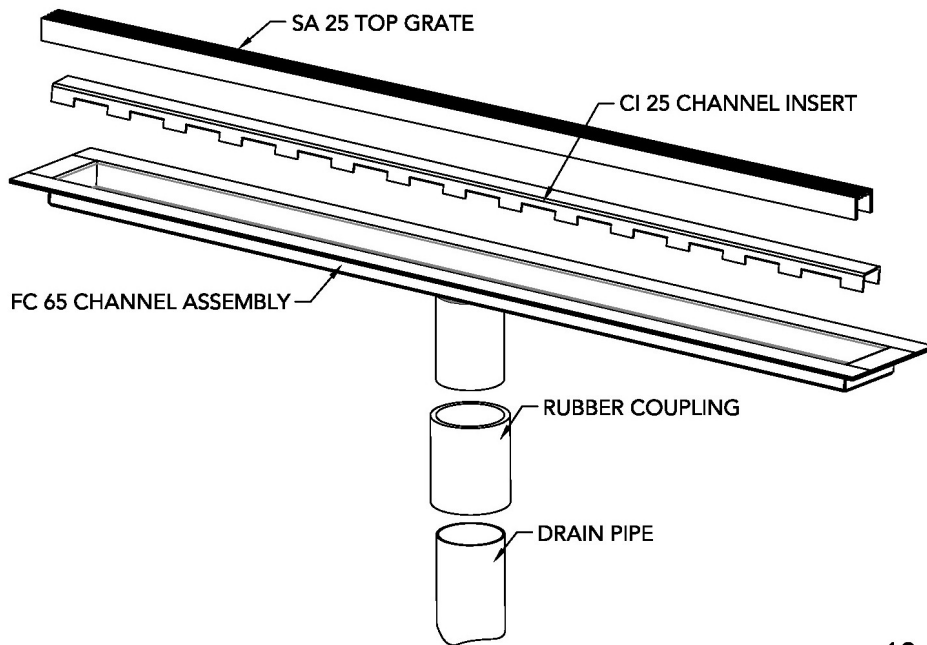
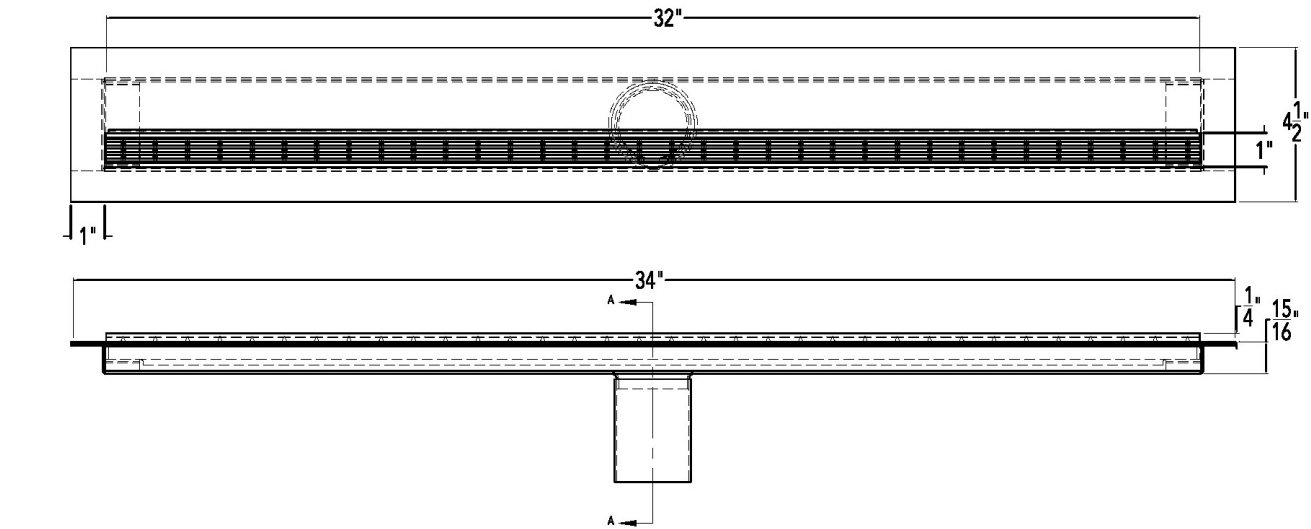

- FFAS 2532**  
**32" Complete Kit Includes:**  
 (34 1/8" l x 4 1/2" w x 4 13/16" h)  
 1 - SA 2532 Grate  
 1 - FC 6532 Fixed Flange Channel  
 1 - CI 2532 Channel Insert

**Infinity Drain**  
 18 Secatoag Avenue  
 Port Washington, NY 11050  
 Phone: 516.767.6786  
 Fax: 516.740.3066  
 www.InfinityDrain.com

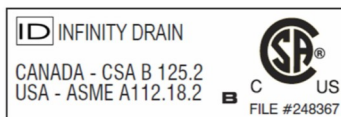

**Note:** Installer must verify all rough-in dimensions prior to installation and consult local and national codes. Conformity and compliance to local and national codes are the responsibility of the installer.

# FFAS 2536 Specifications

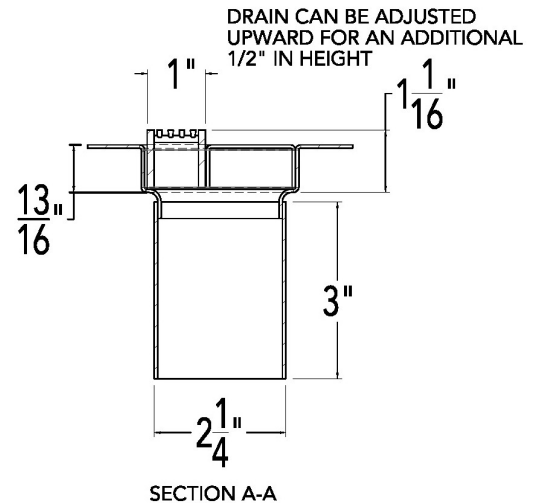
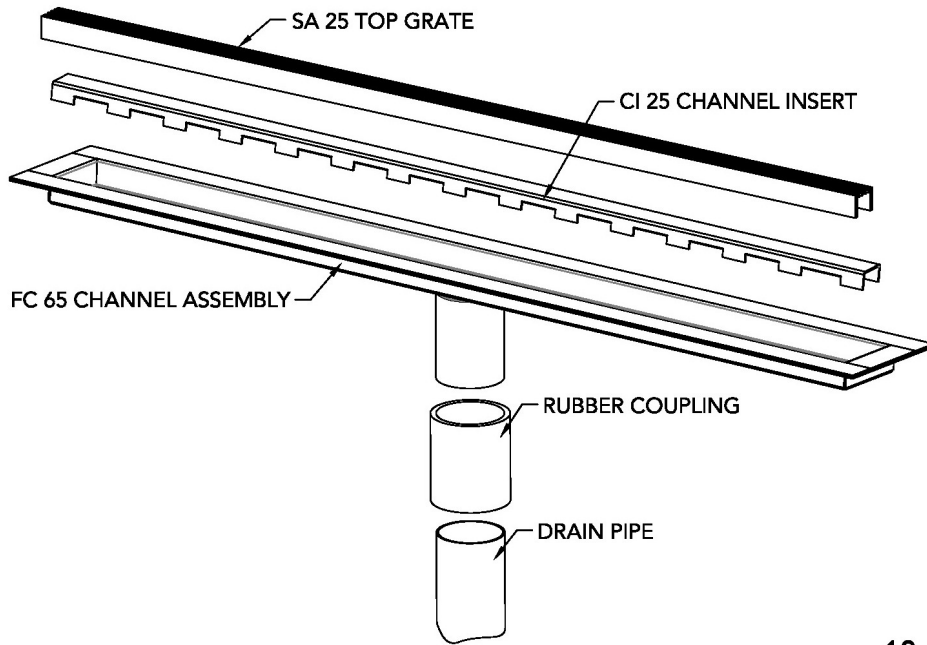
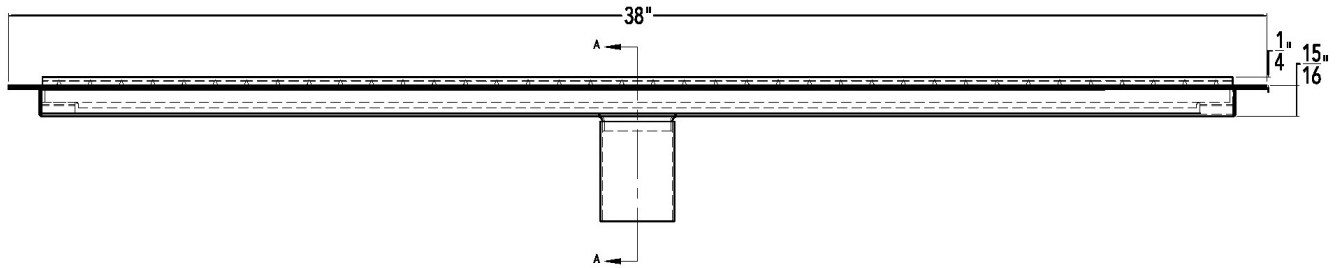
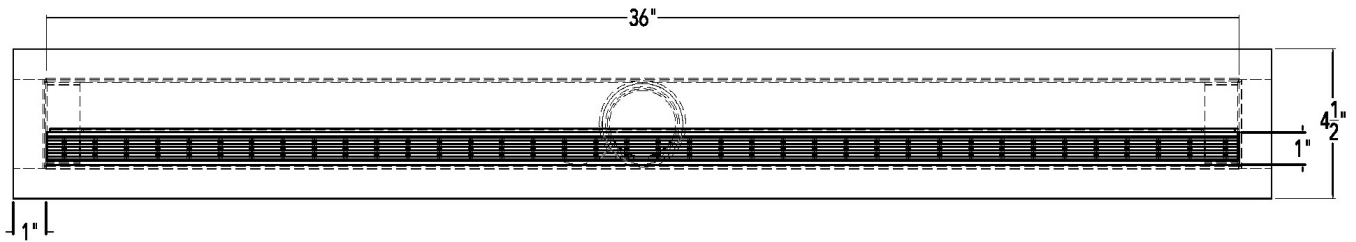

## FFAS 2536

### 36" Complete Kit Includes:

(38 1/8" l x 4 1/2" w x 4 13/16" h)

1 - SA 2536 Grate

1 - FC 6536 Fixed Flange Channel

1 - CI 2536 Channel Insert

## Infinity Drain

18 Secatoag Avenue  
 Port Washington, NY 11050  
 Phone: 516.767.6786  
 Fax: 516.740.3066  
 www.InfinityDrain.com

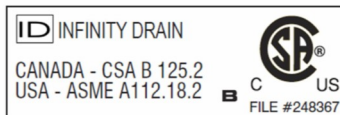

**Note:** Installer must verify all rough-in dimensions prior to installation and consult local and national codes. Conformity and compliance to local and national codes are the responsibility of the installer.

# FFAS 2542 Specifications

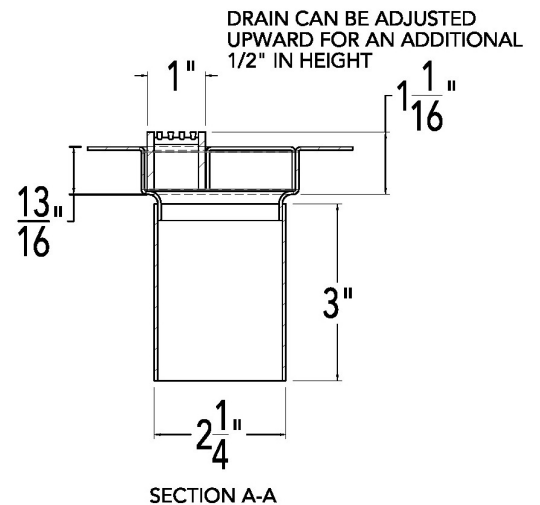
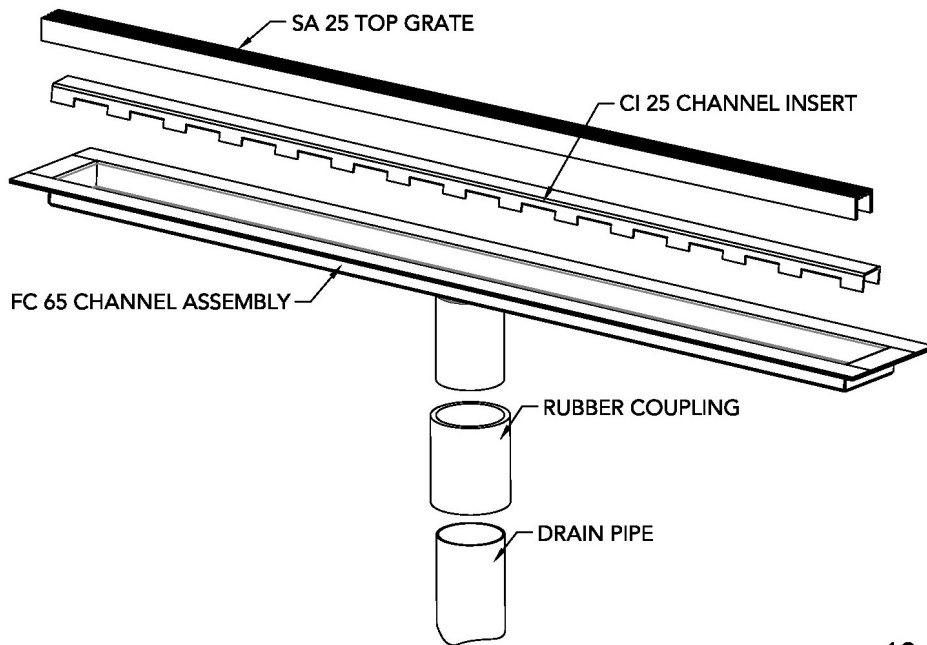
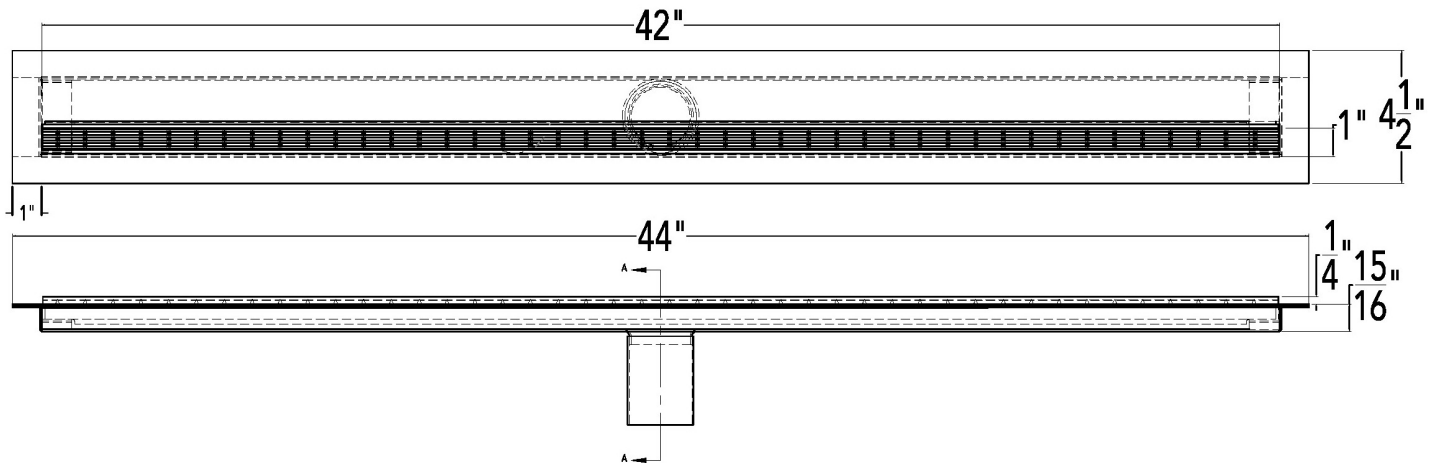

## FFAS 2542

### 42" Complete Kit Includes:

(44 1/8" l x 4 1/2" w x 4 13/16" h)

- 1 - SA 2542 Grate
- 1 - FC 6542 Fixed Flange Channel
- 1 - CI 2542 Channel Insert

## Infinity Drain

18 Secatoag Avenue  
 Port Washington, NY 11050  
 Phone: 516.767.6786  
 Fax: 516.740.3066  
 www.InfinityDrain.com

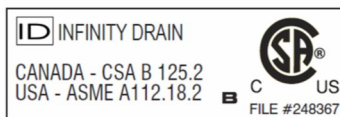

**Note:** Installer must verify all rough-in dimensions prior to installation and consult local and national codes. Conformity and compliance to local and national codes are the responsibility of the installer.

# FFAS 2548 Specifications

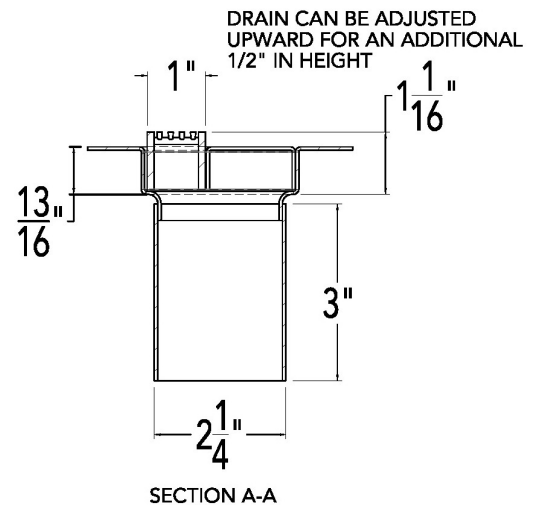
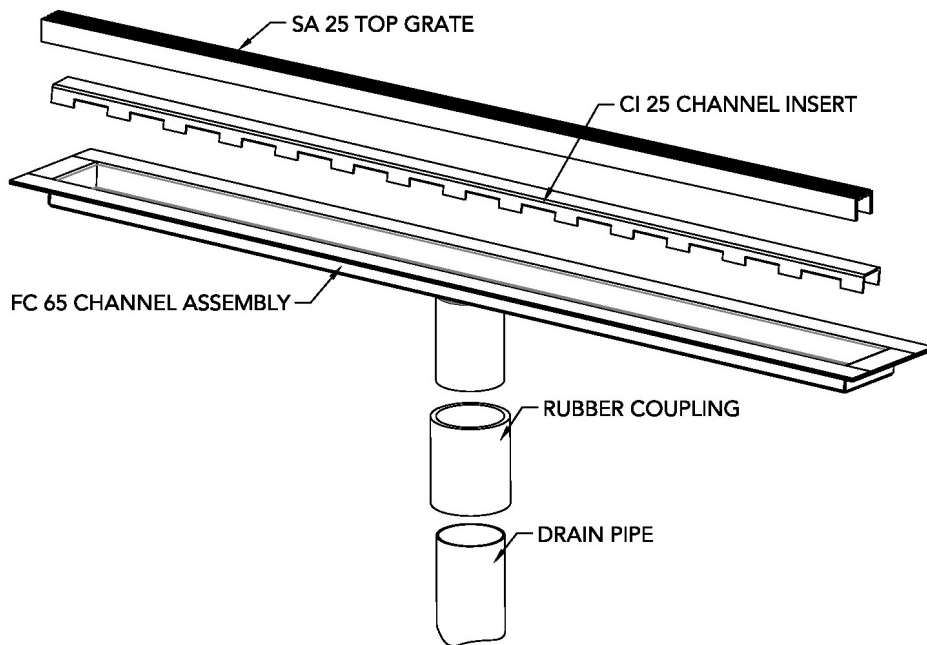
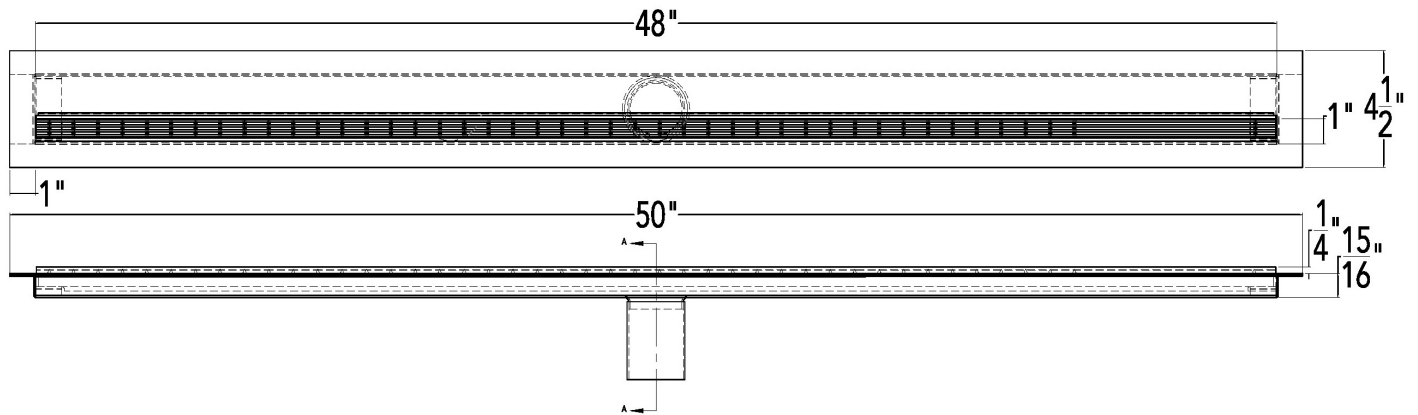

## FFAS 2548

### 48" Complete Kit Includes:

(50 1/8" l x 4 1/2" w x 4 13/16" h)

- 1 - SA 2548 Grate
- 1 - FC 6548 Fixed Flange Channel
- 1 - CI 2548 Channel Insert

## Infinity Drain

18 Secatoag Avenue  
 Port Washington, NY 11050  
 Phone: 516.767.6786  
 Fax: 516.740.3066  
 www.InfinityDrain.com

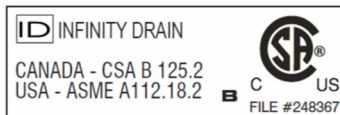

**Note:** Installer must verify all rough-in dimensions prior to installation and consult local and national codes. Conformity and compliance to local and national codes are the responsibility of the installer.

# FFAS 2560 Specifications

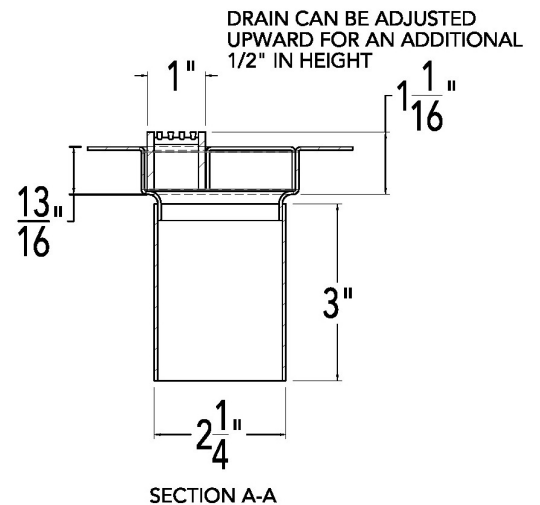
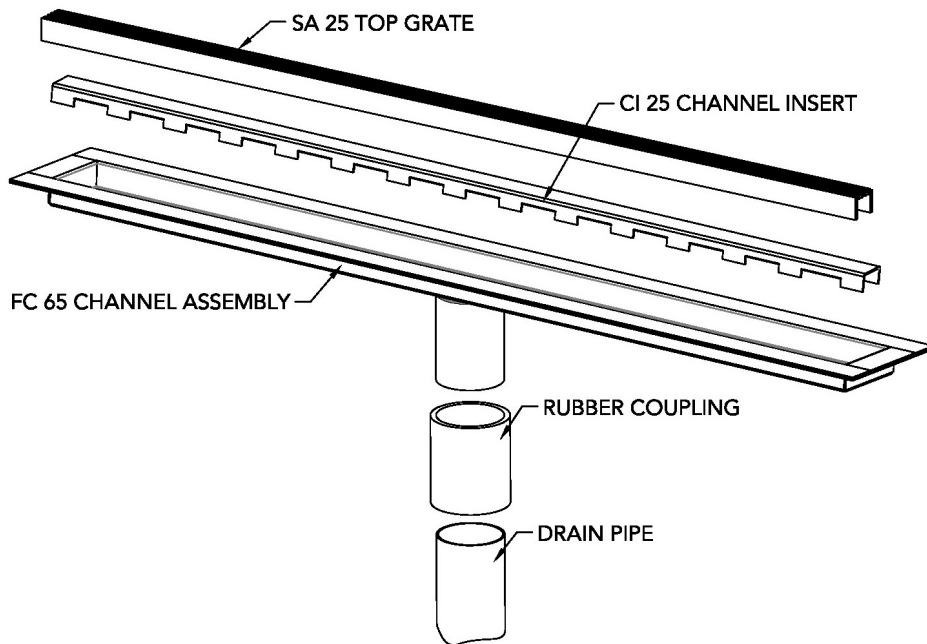
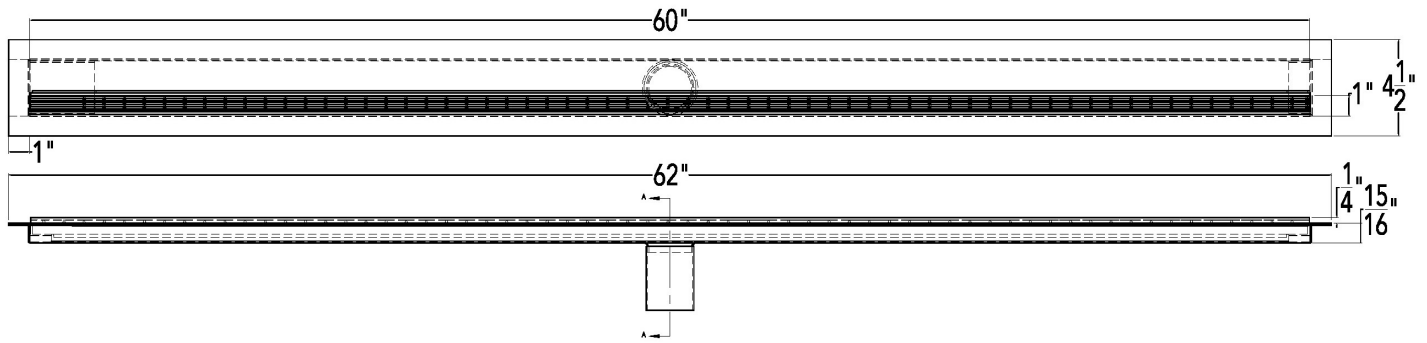

## FFAS 2560

### 60" Complete Kit Includes:

(62 1/8" l x 4 1/2" w x 4 13/16" h)

- 1 - SA 2560 Grate
- 1 - FC 6560 Fixed Flange Channel
- 1 - CI 2560 Channel Insert

## Infinity Drain

18 Secatoag Avenue  
 Port Washington, NY 11050  
 Phone: 516.767.6786  
 Fax: 516.740.3066  
 www.InfinityDrain.com

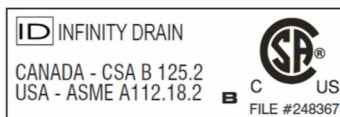

**Note:** Installer must verify all rough-in dimensions prior to installation and consult local and national codes. Conformity and compliance to local and national codes are the responsibility of the installer.