

# TIF Series

# 65 Installation

## Parts List

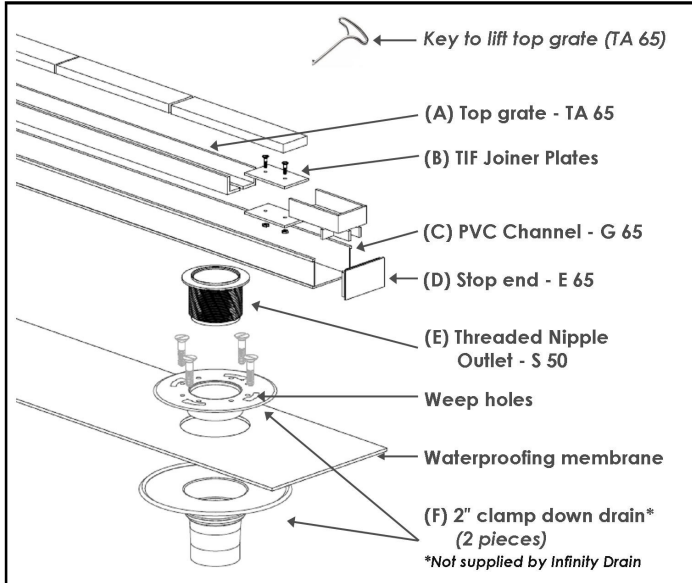

Figure 1

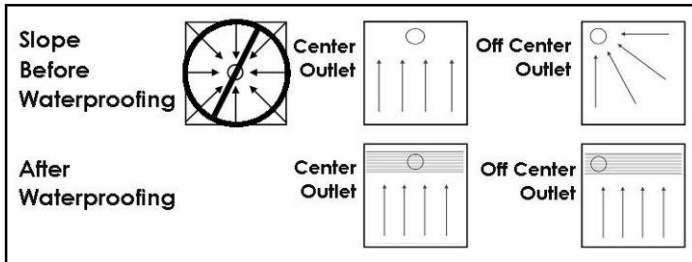

Figure 2

Our linear drains are designed to achieve high flow and have a channel with a neutral pitch, meaning 100% level. This allows you to locate the outlet anywhere on the channel. The water will drain when in the channel and create a siphon until it is drained. There will be a few drops remaining in the channel. The exception would be for a miter installation than it would be necessary to pitch the non-outlet channel towards the outlet channel.

## Determining floor height

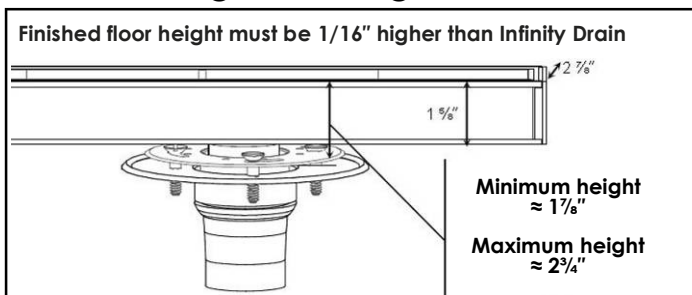
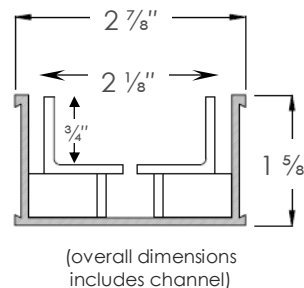

Figure 3

Clamp down drain not supplied by Infinity Drain

- Determine drain location.
- Set height with threaded nipple outlet (E) into clamp down drain (F) and roughly estimate desired height. *Note: Product is designed to achieve high flow with no channel pitch. (\*clamp down drain not supplied by Infinity Drain. Must use local listed clamp down drain with 2" female throat (spud).)*
- Cut channel to size (C) (if necessary). When measuring overall channel length, allow 3/16" for both stop ends (D) to fit.
- Affix the stop ends to the channel. Use clear PVC primer solvent and cement to ensure a tight fit with no gaps. *Take care, as this is a permanent adhesion and cannot be removed without damaging the stop end fittings.*
- Using a 2 1/4" hole saw, cut a hole in the base of the channel (C) where the threaded nipple outlet (E) will be located. *\*Once assembled, confirm height before affixing outlet to channel. Finished floor must be 1/16" higher than Infinity Drain.*
- Create a bed of mortar the length of the channel, on the waterproofing membrane to support the underside of the channel when leveling.
- Set channel (C) in place and make certain channel is absolutely leveled.
- Affix the outlet (E) to the underside of the channel (C) with clear PVC primer solvent and cement. Ensure a tight fit into channel with no gaps.
- If tile insert frame (A) needs to be shortened, cut a 4" section from one end and set aside. Now, cut from the long section of the tile insert frame (A) at the open end to desired length minus 4", then reattach the 4" end section with the TIF joiner plates (B) and tighten the two screws.
- When applying mud to floor, allow for thin set and the tile thickness around the channel.
- Use a silicone seal around the outer edges of the channel before tiling.
- Ensure grate remains in channel during mud application and tiling to prevent channel from flexing. Please take measures to protect the stainless steel grate when applying cement and/or grout in channel area.
- Tile floor must be 1/16" above channel edge.
- Use a mix of 50% clear PVC cement and 50% dry grout to cover visible edge of the channel, and apply immediately. PVC primer solvent should be used on the channel edges before applying PVC/grout mix.
- Allow to set for 36 hours before using.

Infinity Drain recommends this product be installed by a licensed contractor.



TIF 65

Figure 4