

FX Series

FXED, FXAS & FXTIF Installation

Parts List

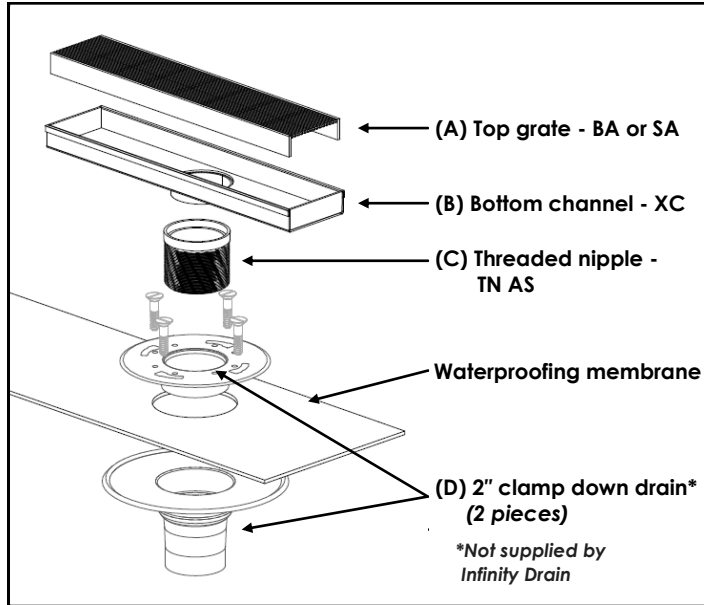

Figure 1

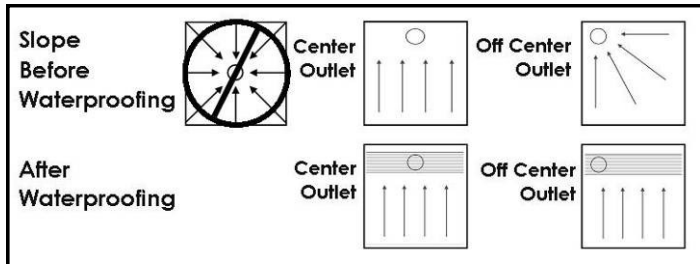

Figure 2

Installation Instructions

1. Determine clamp down drain **(D)** location.
2. Screw threaded nipple **(C)** into clamp down drain **(D)**. Place bottom channel **(B)** into threaded nipple **(C)**. Adjust to desired height. (Tile finished 1/16" higher than channel)
3. Remove bottom channel **(B)** and lay a bed of mortar below channel length. Apply a bead of silicone to outside of the channel **(B)** outlet, then press channel **(B)** outlet into threaded nipple **(C)** to create a seal.
4. Confirm that channel **(B)** is leveled.
5. Spread mortar bed, slope 1/4" per foot away from drain in a single plane. Note: tile height finishes 1/16" higher than grate height.
6. Prior to tiling, run a bead of silicone around the channel edge.
7. Finish tiling, allowing tile to finish 1/16" higher than channel/grate.
8. Allow to set for 36 hours before using.

Infinity Drain recommends this product be installed by a licensed contractor

Determining floor height

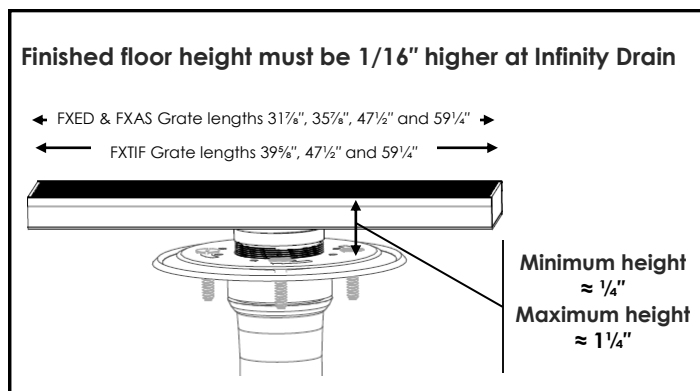

Figure 3

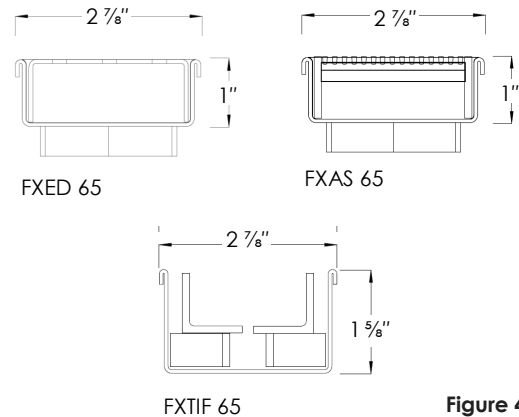

Figure 4

Clamp down drain is not supplied by Infinity Drain