

AS Series

65 Installation

Parts List

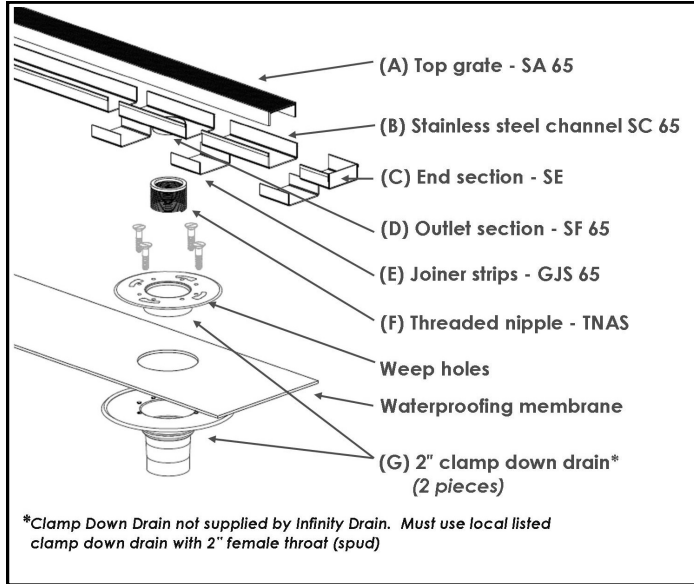

Figure 1

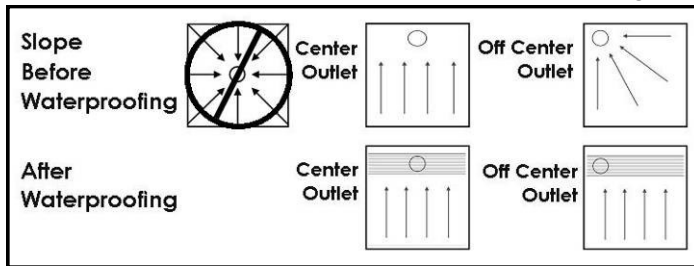

Figure 2

Our linear drains are designed to achieve high flow and have a channel with a neutral pitch, meaning 100% level. This allows you to locate the outlet anywhere on the channel. The water will drain when in the channel and create a siphon until it is drained. The exception would be for a miter installation then it would be necessary to pitch the non-outlet channel towards the outlet channel.

Determining floor height

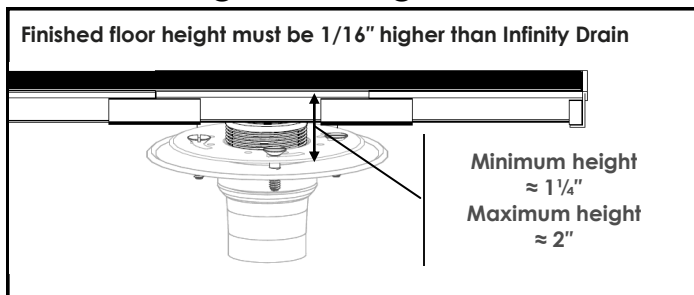
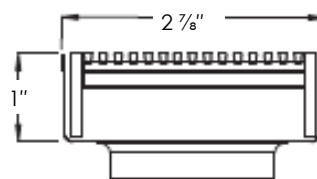

Figure 3

Clamp down drain not supplied by Infinity Drain

1. Determine drain location.
2. Set height with threaded nipple **(F)** into clamp down drain* **(G)** and roughly estimate desired height. *Note: Product is designed to achieve high flow with no channel pitch. (*clamp down drain not supplied by Infinity Drain. Must use local listed clamp down drain with 2" female throat (spud).)*
3. Position the outlet section **(D)** into the threaded nipple **(F)**.
4. Cut channel **(B)** where outlet **(D)** is to be adapted to the channel. *Note: The AS 65 Series is site sizeable. For smaller lengths, cut channel to size desired. Note: Outlet **(D)** is 6" ± 1/4" and the end sections **(C)**, are 4 1/8" ± 1/4" total (2 1/16" ± 1/4" each) To cut channel use a hacksaw with a 32 teeth blade. Ensure cut is square. Gently file back rough edges.*
5. Lay out components to determine fit on a flat surfaced area, including the grates.
6. Test join channel **(B)** with end section **(C)**, with outlet **(D)** using joiner strips **(E)**. Also insert grates to ensure fit. Recheck height, length and outlet position.
7. Once correct, clean all parts with denatured alcohol, then use construction sealant, Sikaflex 1a, provided by Infinity Drain. Apply Sikaflex to all joining parts and re-assemble for final installation. Let dry overnight.
8. Once assembled, confirm height by turning threaded nipple **(F)**.
9. Create mortar bed the length of the channel, to support the channel when leveling. Apply a bead of Sikaflex around outlet **(D)** before inserting into threaded nipple **(F)** to create a seal.
10. If grate **(A)** needs to be shorted, use a hacksaw with a 32 teeth blade to cut grate to size.
11. Ensure grate remains in channel during tiling to prevent channel from flexing. Please take measures to protect the stainless steel grate when applying cement and/or grout in the channel area.
12. Use a silicone seal around outer edge of the channel.
13. Finished floor must be 1/16" above channel edge.

Infinity Drain recommends this product be installed by a licensed contractor.



(overall dimensions includes channel)



AS65

Figure 4